

Concrete Path Open Space A110.04



DESIGN STATEMENT

The standard for main circulation paths in parks is for a grey concrete footpath with sawcut control joints and a broom finish. The width of pathway will vary between 1.5 metres and 3.0 metres depending on the park path hierarchy and whether it is a shared use path that also provides for bicycles.

APPLICABLE LOCATION

Moreland parks and sportsgrounds

COUNCIL STANDARD DRAWING

N/A

CROSS REFERENCE DOCUMENT

- N/A

STANDARD SPECIFICATION

N/A

SUPPLIER

N/A

MAINTENANCE

N/A

GENERAL NOTE

1. "T" = 100mm with SL62 reinforcement fabric placed at 30mm cover. "T" = 125mm with SL72 reinforcement fabric placed at 30mm cover, where shared path abuts kerb and/or kerb & channel, or across maintenance vehicle tracks.
2. Provide contraction joints at 1.5m intervals and expansion joints at 15m intervals. The joints to be at right angles to the direction of the shared path unless specified otherwise and to be in accordance with SD291 and Technote A200.02. Expansion joints shall not have dowels.
3. Where an existing section of shared path is to be reinstated, the section to be replaced shall be between existing joints.
4. Concrete shall be ready mix in accordance with relevant Australian Standards and shall have a 28 day compressive strength of 25 MPa minimum.
5. All concrete shared paths should be a minimum of 2400mm wide with a rough broom finish.
6. Saw or wet formed contraction joints should be at 1500mm centres. Expansion joints should be provided at 15 metre centres.

A110.04 Concrete Path Open Space

RECREATIONAL CONCRETE PATH 3m WIDE

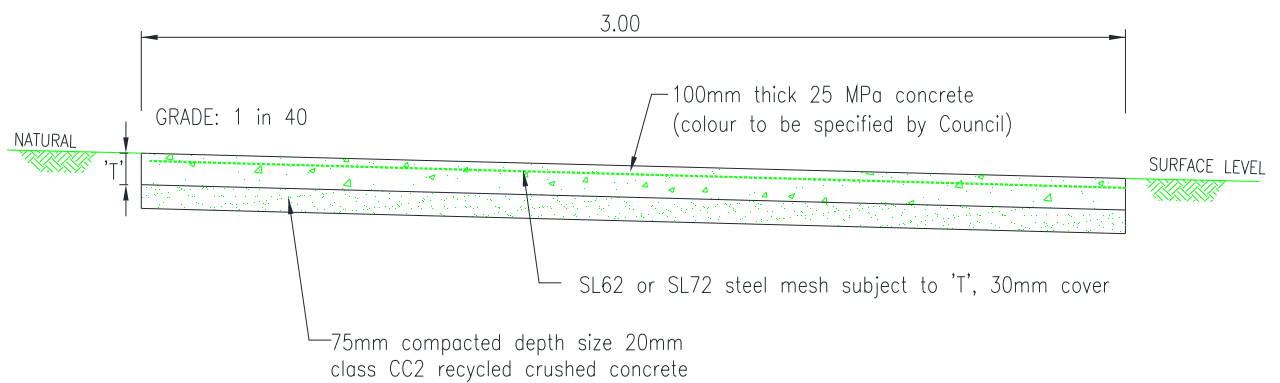

CONCRETE FOOTPATH

